



Review

A review of the safety of MRI in cochlear implant patients with retained magnets



R. Srinivasan^a, C.W. So^b, N. Amin^c, D. Jaikaransingh^d, F. D'Arco^e,
R. Nash^{f,*}

^a Department of Radiology, Guy's & St Thomas' Hospital, London, UK

^b Department of Radiology, Northwick Park Hospital, London, UK

^c Department of ENT, St George's Hospital, London, UK

^d St George's Medical School, London, UK

^e Department of Radiology, Great Ormond Street Hospital, London, UK

^f Cochlear Implant Department, Great Ormond Street Hospital, London, UK

ARTICLE INFORMATION

Article history:

Received 22 April 2019

Accepted 12 June 2019

The number of patients with cochlear implants (CIs) is increasing due to expanding indications, and improving CI services. Furthermore, as the use of imaging increases in clinical medicine, it is increasingly likely that patients with CIs will require a magnetic resonance imaging (MRI) examination during their lifetime. Therefore it is important that clinicians are aware of the safety aspects and manufacturer recommendations for CI patients with retained magnets. This article summarises guidelines from all major CI manufacturers and reviews the published literature on the safety of MRI in CI patients with magnets *in situ*. The most commonly reported complication of MRI in CI patients was pain. Other significant complications included magnet displacement, depolarisation, and polarity reversal. Artefacts caused by the CI remain an issue, but may be reduced by the use of specific sequences. Manufacturer recommendations should be followed to reduce the risk of complications, although complications may occur even when guidelines are followed. For this reason, the indication for imaging these patients should be reviewed, and patients should be appropriately counselled and consented.

© 2019 The Royal College of Radiologists. Published by Elsevier Ltd. All rights reserved.

Introduction

Cochlear implantation

Cochlear implantation is an operation performed for the rehabilitation of severe to profound hearing loss. In addition

to insertion of an electrode into the cochlea, it involves the placement of an implant package between the temporalis and calvarium. The implant package includes a receiver–stimulator, an antenna, and a magnet connected to an electrode that is inserted into the cochlea. The magnet is required to hold the antenna from an external processor to the skin, and thus enable communication between the external processor, which receives its input from a microphone, and the internal implant package.

The number of cochlear implantations performed worldwide has increased steadily over the last 30 years.

* Guarantor and correspondent: R. Nash, Cochlear Implant Department, Great Ormond Street Hospital, London, UK.

E-mail address: mr.robert.nash@gmail.com (R. Nash).

There are over 400,000 patients with cochlear implants (CIs), and the rate of cochlear implantation is increasing at 9% per annum.¹ Factors behind the increase in cochlear implantation include an ageing population, an increased recognition of the cognitive consequences of hearing loss,² expanding indications, and increased availability of CI services.³

Magnetic resonance imaging

Magnetic resonance imaging (MRI) is a commonly employed imaging method that is predominantly used for the visualisation and characterisation of soft tissues. It involves static and dynamic magnetic fields through the use of an electromagnet and radiofrequency energy. In 2000, it was estimated that the lifetime incidence of a neurological disorder likely to require investigation with MRI was 6%.⁴ Since that time, the use of MRI has expanded greatly, particularly in non-neurological applications such as cardiac MRI, and imaging of the abdomen, pelvis, and musculoskeletal system. The use of MRI is expanding at approximately 20% per annum (Fig 1).

MRI in patients with CI

Patients with CIs are particularly likely to require an MRI examination. A 2015 survey of 482 patients with CI revealed that 9.8% of patients had undergone MRI.⁵ This may be due to the aetiology of hearing loss, such as neurofibromatosis type 2, where vestibular schwannomas may have to be monitored with MRI. This may also be due to complications associated with CIs, such as meningitis and its sequelae. Lastly, it may be due to associations between the cause of hearing loss and other conditions, for example in patients with CHARGE syndrome (which is characterised by, among other features, coloboma, heart defects, atresia choanae, retardation of growth and development, genitourinary dysplasia, and ear anomalies).

It is therefore likely that there will be an increasing number of patients with CIs who will be increasingly likely

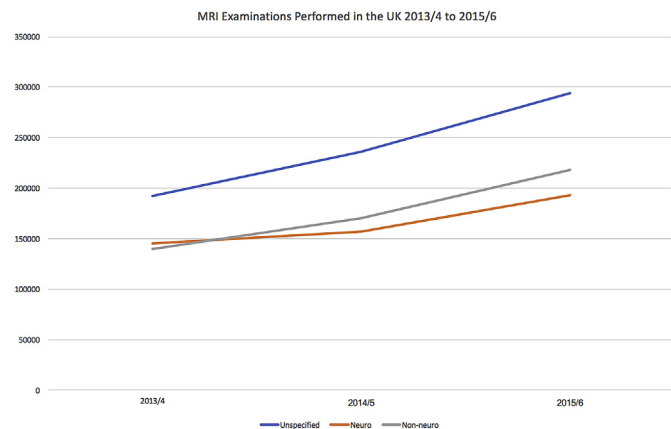

Figure 1 The number of attendances for MRI examinations in the UK National Health Service between 2013/4 and 2015/6 financial years. Source: Hospital Episode Statistics (HES).

to require an MRI examination. MRI in patients with CIs can present numerous challenges due to the ferromagnetic component of the CI system. Particular issues include demagnetisation, rotational and linear forces on the magnet, temperature changes, induced voltages, and imaging artefact. CI should not, however, be considered an absolute contraindication to MRI. Fig 2 is a labelled lateral skull radiograph of a patient with bilateral CIs.

Objectives

Advancements in CI technology, manufacturer published guidelines, and *in vivo* and *in vitro* studies have allowed increasingly safe imaging when certain criteria are fulfilled. The aim of this article is to review the literature on MRI in patients with CI. It outlines and discusses the major issues that may be encountered in imaging these patients. It goes on to provide manufacturer recommendations for scanning patients with CIs with and without magnets *in situ*. The article also reviews published evidence into the safety of MRI in patients with CIs.

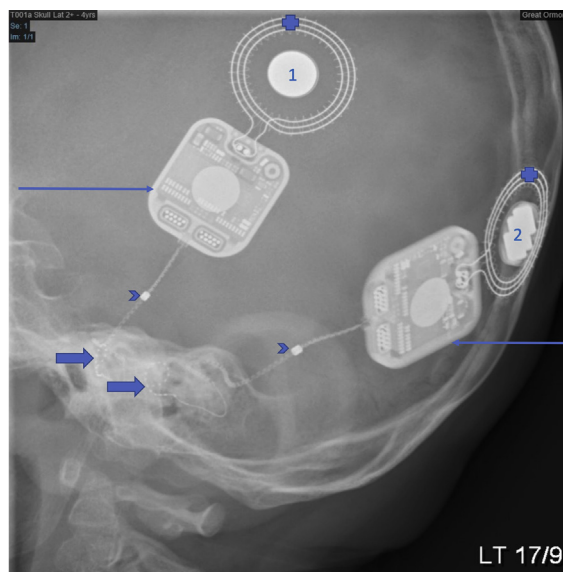

Figure 2 Lateral skull radiograph of a patient with bilateral CIs. The right-sided implant¹ is an Advanced Bionics (AB) Ultra package, and the left-sided implant² is an AB 3D Ultra package. The stimulator receiver packages are marked with an arrow, the intra-cochlear electrodes with a short arrow. The angulation obscures the spiral position of the electrodes. The coils are denoted with crosses and the reference electrodes with chevrons. In routine clinical practice, these parts are relatively unaffected by MRI. Induced voltages and consequent heating may limit sequences, and the package will create an artefact, even in the absence of a magnet, but otherwise these components are not problematic. The disc magnet¹ lies in parallel to the skull, but in a conventional supine position, the MRI static field will create a rotational force to move the magnet to a perpendicular position, which has the potential to cause pain and magnet displacement. The 3D Ultra package magnet² has freely rotating magnetised cylinders that align with the static magnetic field of the MRI, which prevent rotational forces being exerted on the magnet.

Issues encountered undertaking MRI in patients with CIs

Rotational and linear forces

Although the MRI machine will exert linear forces on the CI magnet, which has the potential to cause superior displacement of the implant, this is less problematic than the rotational force the MRI will exert on the CI magnet. The reasons for this are principally to do with the alignment of the magnetic field; however, directional displacement of the implant is likely to be less painful, is less damaging to the implant package, and is more restricted by fibrosis around the CI.

The principal effect of the magnetic field will be the attempt to align the magnetic field of the CI magnet with the field of the MRI scanner. In most models of CI this exerts a rotational force on the implant magnet in an attempt to move it to a position perpendicular to its usual resting position when a patient is lying supine.⁶ This will cause pain and may damage the implant and surrounding soft tissues.⁷

The greatest force is not within the machine itself, but rather around the inner aspect of the bore of the magnet (Fig 3). This is the area with the greatest spatial gradient, and thus the area where most rotational force may be applied to the magnet.⁸ Particular care should be taken to avoid this area, and in particular, avoid repositioning in the bore. It is likely that the rotational force on the implant, and thus its propensity to displace the magnet and cause pain, is greater during head MRI examinations compared to other body parts as the CI is in closer proximity to the scanner.⁵

Torque was initially identified as the most serious issue associated with MRI in patients with CIs.⁹ A technique proposed to minimise magnetic force involves positioning the patient supine on a trolley away from the MRI machine, and then slowly bringing the patient to the machine without repositioning.⁸ Manufacturers have also addressed this problem by recommending tight head wrapping to restrict rotation of the implant magnet, and also developing freely rotating magnets that align with the MRI magnetic field and thus do not have a rotational force applied to them. Another approach has been to develop devices that can be

firmly secured to the calvarium with screws to prevent rotational movement, even when a rotational force is applied.

Demagnetisation

Demagnetisation depends principally on the interaction of the magnetic field of the CI magnet and the static magnetic field of the MRI. Therefore, the variables that affect demagnetisation include the strengths of the magnet in the MRI and CI, the angulation between the MRI static field and the CI magnetic field, and the duration of the exposure. The consequence of demagnetisation depends on its degree, and varies from being required to wear a more powerful external magnet, through to attempting to secure the external antenna sufficiently close to the package with the use of hair clips, headbands, or adhesives, or performing revision surgery. Clinically, demagnetisation is seen exceptionally rarely, as patients likely to need many MRI examinations may receive devices that are more compatible with scanning, or indeed devices with no magnet, which necessitate the aforementioned clips, adhesives, and headbands to hold them in place.

The approaches that can be taken to limit demagnetisation include limiting the strength of the magnetic field (i.e., only allowing the device to be used with 1.5 T MRI), limiting the time the patient spends in the MRI machine, or specifying angulation between the implant and the magnetic field of the MRI. Rotating magnets can align with the MRI magnetic field, and thus will not undergo demagnetisation.

Heating and induced voltages

Heating of the implant occurs as a result of induced electrical currents caused by dynamic magnetic gradient fields associated with radiofrequency stimulation. This stimulation, and consequently, the induced voltages and heating, depend on the specific sequences used. In theory, this process could affect the function of the implant, or cause localised tissue damage, but this has not been seen in clinical practice.

The ability of MRI on a CI to heat fluid has been investigated^{10,11}; however, there are no *in vivo* or *in vitro* studies

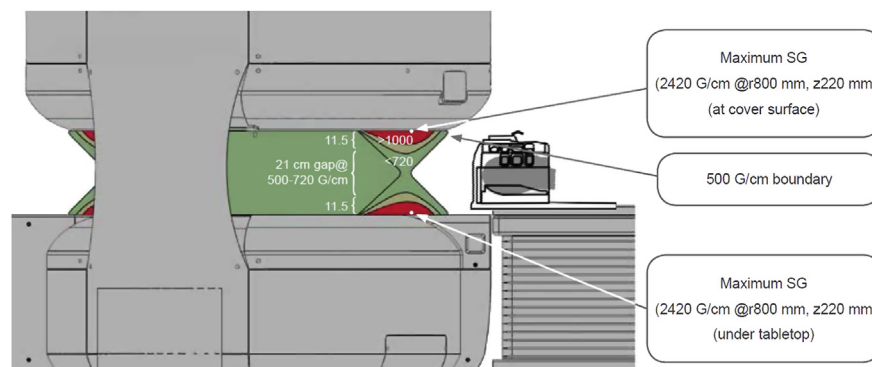

Figure 3 Schematic showing the distribution of spatial gradient (SG) in an MRI scanner. The green shade represents lowest SG values, whereas the tan and red zones have higher SG values. Reproduced with permission from Hitachi Medical systems, USA.

demonstrating the effects of such heating. Nevertheless, it is generally considered that heating up to 1°C is safe.¹² Practices and recommendations that limit heating include limitations to specific absorption rate (SAR).

Imaging artefact

Artefact is an unavoidable consequence of imaging patients with metallic implants. This is the case both for computed tomography (CT) and MRI. The intrinsic magnet is particularly problematic for MRI, but other metallic components of the CI package can also lead to localised distortion. If artefact makes the investigation non-diagnostic, then even a safely performed MRI is counterproductive.

Artefact from CI magnets is typically due to localised variation in the magnetic field, leading the scanner to misattribute signal to nearby areas. This means in addition to an area with no viable signal, there is also distortion of nearby anatomical structures (Fig 4).

Artefact from the CI can be managed by the selection of specific imaging techniques designed to reduce metallic artefact, such as slice encoding magnetic artefact compensation (SEMAC), which are based on a two-dimensional (2D) turbo spin echo sequence. These may be more time-consuming, and therefore, heating and demagnetisation should be considered; however, they are particularly useful if the area of interest for imaging is in proximity to the CI. The most common scenario in which this is the case is in pathology of the internal acoustic meatus (IAM). Tumours of the IAM characteristically present with hearing loss, and ipsilateral cochlear implantation is an option for a subset of these patients, particularly those with neurofibromatosis type 2. Placing implants very posteriorly at the time of surgery may allow visualisation of the IAM to be preserved,¹³ as the distance between the magnet and the structure being visualised is the most important factor in determining artefact, although angulation may also play a role.¹⁴

There are sequences that are highly susceptible to artefact, for example, diffusion-weighted sequences. The artefact seen in these sequences may obscure much of the ipsilateral intracranial space. T1-weighted sequences may also be more affected than T2-weighted sequences. Imaging

at 3 T may exacerbate artefacts. If a patient requires diagnostic imaging of an area obscured by artefact from a pre-existing CI, a clinical decision needs to be made about the benefits and risks of removal of the implant magnet, or even removal of the implant package.

Removal of the implant magnet can be conducted with a small incision over the implant. This has been conducted under local anaesthetic in an adult population.^{15,16} A device-specific non-magnetic spacer is placed to prevent soft tissue from filling the magnet pocket. There is a risk of infection, which may lead to explantation, and also of compromising the hermeticity of the package and inducing CI failure. If the area of interest is in immediate proximity to the CI, then the package can be removed, although the electrode is usually left in place in order to facilitate future re-implantation. Fig 5 demonstrates the artefact encountered when imaging CIs with magnet removed using various sequences.

Manufacturer guidelines

The large majority (79%) of MRI systems in the UK are 1.5 T, although 3 T systems currently account for 17%.¹⁷ There are multiple CI models available that are deemed by the manufacturer to be MRI compatible without need for the removal of the magnet at 1.5 T. Each manufacturer takes a slightly different approach to imaging guidelines in terms of the parameters they choose to limit: field strength, SAR, spatial gradient fields, and time between surgery and imaging.

Cochlear Ltd

Cochlear is a large CI manufacturer that is based in Australia. They have been in operation since 1981, and thus have a range of historical models. Their implants are included in the majority of clinical published series,^{6,8,18–21} which may be a reflection of their relative market share. The manufacturer guidelines for MRI with their implants are shown in Table 1.

Depending on the model, MRI can be performed at 1.5 T with or without temporary removal of the magnet. The magnet must be removed in all models if scanning at 3 T; however, the manufacturer also recommends that the

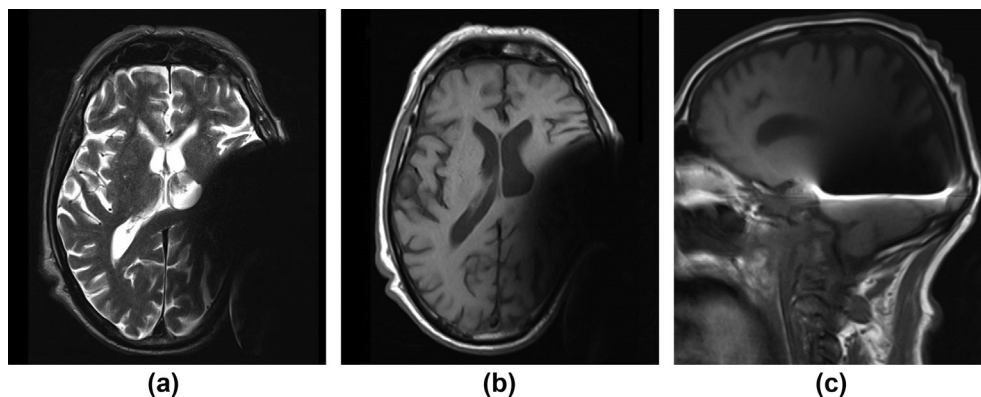

Figure 4 (a) Axial T2-weighted, (b) axial T1-weighted, and (c) sagittal-T1 weighted imaging in a CI patient with retained rotating magnet, exhibiting significant intravoxel dephasing and geometric distortion.

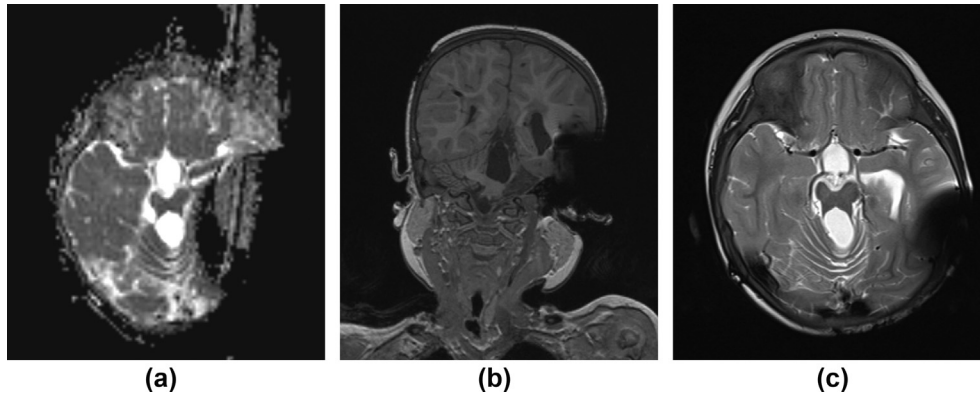

Figure 5 (a) Axial diffusion-weighted, (b) coronal T1-weighted, and (c) axial T2-weighted imaging in a CI patient with magnet removed and replaced with a dummy magnet. Despite the removal of the magnet, there is moderate metal artefact due to the radiofrequency antenna and receiver stimulator.

magnet also be removed if the diagnostic area of interest is near the implant. The company can provide a bandage and splint kit for MRI examinations. The splint should be placed over the magnet, with an elasticised compression bandage wrapped around the head at least twice.

Advanced Bionics

Advanced Bionics, part of the Sonova Holdings, is a major CI manufacturer, based in the United States. They have recently developed a CI with four rotating cylindrical magnets to improve MRI compatibility. The manufacturer guidelines for MRI with their implants are shown in [Table 2](#).

The HiRes Ultra and the HiRes Ultra 3D are the only CIs currently available from Advanced Bionics that can be scanned at 3 T. The HiRes Ultra 3D contains four rotatable magnets held in a revolving disc that allows the magnet to align with the MRI magnetic field. The HiRes Ultra 3D can be scanned at 3 T with the magnet *in situ* and without the need of a compression bandage. An MRI antenna coil cover, as part of their bandaging protocol is advised for other models. The manufacturer recommends that the CI is *in situ* for 2–4 weeks after insertion prior to an MRI examination.

MED-EL

MED-EL is a major CI manufacturer based in Austria. They developed the first commercially available CI with a freely rotating magnet for MRI compatibility. The

manufacturer guidelines for MRI with their implants are shown in [Table 3](#).

The Synchrony models have a freely rotating, self-aligning magnet that reduces torque effect. The manufacturer deems that the magnet can be left in place for an MRI to be performed up to and including 3 T. The use of a supportive head bandage with the Synchrony models is deemed optional by the manufacturer. The Concerto, Sonata, Pulsar, and C40 models can be scanned in a field strength up to 1.5 T with the magnet in place. Contrary to the Synchrony, use of a supportive head bandage is deemed necessary; MED-EL guidelines recommend a bandage wrapped tightly around the head at least three times. The patient is advised not to tilt their head relative to the long axis of the body.

Oticon

Oticon is a Danish company with an extensive background in hearing aid development. They acquired the French CI manufacturer Neurelec in 2013. They have developed an implant that is secured to the skull with screws to prevent rotational movement when undergoing MRI. The manufacturer guidelines for MRI with their implants are shown in [Table 4](#).

The Neuro ZTi model can be scanned in a field strength of up to 1.5 T with the magnet or 3 T with the magnet removed. Use of a head bandage is recommended and the patient should enter the tunnel head first. The Neuro ZTi

Table 1
Guidelines on scanning cochlear branded cochlear implants.

Cochlear model	Maximum MRI field strength (T)	Max spatial gradient (T/m)	Whole body average SAR (W/kg)	Head average SAR (W/kg)	Magnet removal	Head bandage
CI512, CI522, CI532, CI422, CI24REH, CI24RE (CA), CI24TE (ST)	1.5	20	<1	<1	Not required	Mandatory
	3	20	<0.5	<1	Required	Not required
CI24R (CA), CI24R (CS), CI24R (ST), CI24M,	1.5	20	1	1	Not required	Mandatory
CI24R (CA), CI24R (CS), CI24R (ST), CI24M,	3	20	0.5	1	Required	Not required

CI22M is contraindicated for MRI. No CI22M implants were implanted within Europe. CI11+11+2M is contraindicated for MRI.

Table 2

Guidelines on scanning Advanced Bionics branded cochlear implants.

Advanced Bionics model	Maximum MRI field strength (T)	Max spatial gradient (T/m)	Whole body average SAR (W/kg)	Head average SAR (W/kg)	Magnet removal	Head bandage
HiRes Ultra	1.5	3.47 (with magnet) 13.90 (magnet removed)	≤2	≤3.2	Not required	Mandatory
	3	6.9	≤2	≤2.6	Required	N/A
HiRes Ultra 3D	1.5	20	≤2	≤3.2	Not required	Not required
	3	20	≤2	≤2.6	Not required	Not required
HiRes 90K Advantage; HiRes 90K	1.5	2.5	≤1.7	≤1	Not required	Mandatory

Patients should not be scanned within 2–4 weeks post implantation. There is no restriction of angulation of the head with the HiRes Ultra 3D.

implant should be in place at least 6 months prior to MRI. The manufacturer advises not to use the head coil array with the Neuro ZTi. The Digisonic model can be scanned up to a maximum of 1.5 T with or without the magnet.

Reported series and complications

A review of the literature reveals a reported overall significant complication rate around 15–20%, although this may be subject to recall or reporting bias. The most common complication arising due to MRI in patients with a CI with the magnet *in situ* is pain leading to termination of the scan. Displacement of the magnet, which may require revision surgery, polarity reversal, and silastic tears have also been reported.^{19,22}

The Med-El Synchrony and Advanced Bionics 3D Ultra are currently deemed by the manufacturer to be MRI safe in 3 T systems without need for removal of the magnet, and there are no reports of MRI complications in patients being scanned with these devices.

It is important to note that complications may still occur despite nearly all studies adhering to manufacturer protocol. For this reason, it is important that the patient and clinician requesting the imaging are aware of the risks of MRI, and informed consent is obtained.

Pain

The most common complication reported was pain, which was reported by patients in up to 70% of scans⁵; however, pain that prevented completion of an MRI as a

complication is less common, varying between 6–18%.^{8,18,19} Several case reports also recorded pain as a complication^{23–28}; however, certain studies evaluating CIs with freely rotating magnets or screw fixation, reported that patients did not experience any significant pain.^{7,29}

Reported approaches to manage pain beyond head bandaging vary between the reported series. One series²¹ undertook magnet removal for 10/23 MRI investigations, and even then performed 22/23 investigations with sedation or general anaesthesia (in a predominantly paediatric population). Another centre used local anaesthetic at the magnet site to relieve discomfort.³⁰

Magnet displacement

Magnet displacement is a less common complication, and although it is linked to pain, it can be more difficult to manage. Several retrospective studies reported magnet displacement occurring in between 0.6% and 15% of cases. It has also been reported despite the use of a tight head wrap^{5,6,8,19,31}; however, several studies did not report any cases of magnet dislocation.^{7,10,18,22,29,30} The pooled risk of displacement from 10 cohort studies with the magnet left *in situ* from our literature search was approximately 6.5%.^{6–8,18–22,29,30}

Revision surgery was required in cases with complete magnet displacement.^{6,8,19,31} In patients who experienced partial displacement of the internal magnet, a successful attempt at reseating was reported by applying firm pressure on the scalp over the internal magnet.^{5,8} There were no reports of device failure in any of the studies.

Table 3

Guidelines on scanning Med-El branded cochlear implants.

Med-El model	Max MRI field strength (T)	Max spatial gradient (T/m)	Whole body average SAR (W/kg)		Head average SAR (W/kg)	Magnet removal	Head bandage
Mi 1200 Synchrony,	1.5	29	2		3.2	Not required	Optional
Mi 1200 Synchrony PIN,	3 ^a	29	1 (<35 cm from top of head) ^b	2 (>35 cm from top of head) ^b	1.6	Not required	Optional
Mi 1210 Synchrony ST							
Mi1000 Concerto,	1.5	8	2		3.2	Not possible	Mandatory
Mi 1000 Concerto PIN, Sonata Mi1000 Concerto PIN							
PULSAR, C40+	1.5	8	2		3.2	Not possible	Mandatory

The head should be kept straight for 1, 1.5, and 3 T scans. No specific head orientation is required for 0.2 T scans. For Pulsar and C40+ a minimum bone thickness of 0.4 mm below the implant is required.

^a CI variants only. The ABI variant is not approved for 3 T MRI.

^b Head transmit coils or multichannel transmit coils must not be used in case of a 3 T MRI.

Table 4
Guidelines on scanning Oticon branded cochlear implants.

Oticon model	Maximum MRI field strength (T)	Max spatial gradient (T/m)	Whole body average SAR (W/kg)	Head average SAR (W/kg)	Magnet removal	Head bandage
Neuro zti	1.5	14.9	2	3.2	Not required	Mandatory
	3	14.9	2	3.2	Required; replace with dummy magnet	Mandatory
Digisonic	1.5	N/A	N/A	N/A	Not required	Mandatory

MRI should be performed 6 months after implantation. Do not use the head coil array with the Neuro Zti. Patient must be placed head first into the scanner.

Imaging artefacts

A cadaveric study³² examined artefact by scanning heads at 1.5 and 3 T. MRI was performed with and without a CI, and also with a magnetless CI at both 1.5 and 3 T. The study demonstrated that a distinct signal void resulted when an MRI was performed on CI with magnet *in situ*. This resulted in unusable images of the ipsilateral supra and infra-tentorial structures. These artefacts were more pronounced at 3 T compared to 1.5 T, and removal of the magnets significantly increased image quality. In series of clinical practice, however, CI artefacts rarely compromise the diagnostic utility of the study.^{18,19}

One retrospective study³³ evaluated the image quality of 765 MRI brain sequences in 57 patients who underwent MRI with their CI and magnets *in situ*. The study found that fat saturation algorithms were commonly associated with a ring of susceptibility artefact, obscuring both the ipsilateral and contralateral structures. Factors that were found to improve the view of the ipsilateral cerebellopontine angle included high-resolution imaging and a non-axial plane.

In cases where there is a significant compromise in image quality due to artefact, removal of the magnet can be considered as an option,¹⁸ although the CI itself will still cause a small artefact. Surgical planning prior to insertion of the CI to adjust the location to limit artefact near the site of disease that requires monitoring on imaging should also be considered.³⁴ Where fat suppression is required, short tau inversion recovery (STIR) or Dixon techniques provide more reliable fat suppression than standard fat-saturation sequences.³⁴ Avoidance of accelerated acquisitions is also advised, as the receiver coil elements near the internal magnet do not contribute to the spatial encoding. Further, usage of metal artefact reduction techniques and avoidance of the use of echo-planar imaging are also recommended.³⁴

Other reported complications

Other rarer, but potentially major, complications reported in the literature include demagnetisation and polarity reversal. Two studies specifically investigated the level of demagnetisation in 3 T systems,^{10,35} and reported that the risk of significant demagnetisation is 60% when the tilt angle between the CI magnetic field and the main magnetic field is beyond 80° or 90°, respectively; however, it should be noted that both studies evaluated CIs that are not deemed manufacturer safe to undergo MRI at 3 T with the magnet *in situ*, and this complication was not reported in many larger studies.^{8,19} Other studies reported a case of

significant CI demagnetisation that was successfully resolved by increasing the strength of the magnets within the external headpiece transmitter.^{20,21}

Polarity reversal is a rare complication,^{8,19} although it occurred in 17% of cases in one study.²¹ It has been suggested that polarity reversal may be secondary to magnet displacement, and inadvertent inverted replacement. This has been successfully managed by reversing the polarity of the external magnets^{21,36}; however, revision surgery was necessary in other reported cases.^{8,37}

Conclusions

The increase in numbers of CIs being inserted and MRI examinations being performed means there will be increasing numbers of patients with CIs undergoing MRI. It is therefore important that clinicians, radiology departments, CI programmes, and radiologists are aware of the guidelines for imaging these patients. Following manufacturer guidelines can minimise the risk of MRI; however, a significant proportion of patients with fixed magnets will have pain, and a small proportion will have a more serious complication. Surgery to remove a magnet carries risk of infection and damage to the implant; however, implant manufacturers are increasingly developing devices that are firmly secured or have freely rotating magnets, and thus have negligible risk. Even these devices continue to have problematic artefacts. It is important that all patients with CIs are appropriately counselled with regards to these adverse events prior to undergoing MRI.

Conflict of interest

The authors declare no conflict of interest.

Acknowledgements

The authors acknowledge the assistance of Richard Hughes from Advanced Bionics, Kelvin Hawker from Cochlear, Ben Meredith from Med-El, and Maxine Oxford from Oticon for reviewing and confirming the manufacturer guidelines for imaging.

References

1. Technavio. Global cochlear implants market 2018–2022. April 2018. Available at: <https://www.technavio.com/report/global-hearing-implants-market-analysis-share-2018>. [Accessed 19 February 2019].

2. Livingston G, Sommerlad A, Orgeta V, et al. Dementia prevention, intervention, and care. *Lancet* 2017;**390**(10113):2673–734.
3. National Institute for Health and Care Excellence. *Cochlear implants for children and adults with severe to profound deafness — technology appraisal guidance [TA166]*. 2009. Available at: <https://www.nice.org.uk/guidance/ta166/chapter/1-Guidance>. [Accessed 19 February 2019].
4. MacDonald BK. The incidence and lifetime prevalence of neurological disorders in a prospective community-based study in the UK. *Brain* 2002;**123**(4):665–76.
5. Grupe G, Wagner J, Hofmann S, et al. Prevalence and complications of MRI scans of cochlear implant patients. *HNO* 2017;**65**(S1):35–40.
6. Shew M, Wichova H, Lin J, et al. Magnetic resonance imaging with cochlear implants and auditory brainstem implants: are we truly practicing MRI safety? *Laryngoscope* 2019;**129**:482–9.
7. Todt I, Rademacher G, Grupe G, et al. Cochlear implants and 1.5 T MRI scans: the effect of diametrically bipolar magnets and screw fixation on pain. *J Otolaryngol Head Neck Surg* 2018;**47**:11.
8. Carlson ML, Neff BA, Link MJ, et al. Magnetic resonance imaging with cochlear implant magnet in place: safety and imaging quality. *Otol Neurotol* 2015;**36**(6):965–71.
9. Teissl C, Kremser C, Hochmair ES, et al. Magnetic resonance imaging and cochlear implants: compatibility and safety aspects. *J Magn Reson Imag* 1999;**9**(1):26–38.
10. Dubrulle F, Sufana Iancu A, Vincent C, et al. Cochlear implant with a non-removable magnet: preliminary research at 3-T MRI. *Eur Radiol* 2013;**23**(6):1510–8.
11. Vincent C, Ruzza I, Vaneecloo FM, et al. Magnetic resonance imaging with the Digisonic SP Neurelec cochlear implant. *Eur Arch Oto-Rhino-Laryngol* 2008;**265**(9):1043–6.
12. Comité Européen de Normalisation Electrotechnique (CENELEC). *BS EN 45502-2-3:2010 — active implantable medical devices. Part 2-3: particular requirements for cochlear implant systems*. 2010. Available at: <https://cochlearimplanthelp.files.wordpress.com/2016/10/en-45502-2-3-2010.pdf>. [Accessed 19 February 2019].
13. Todt I, Rademacher G, Mittmann P, et al. MRI artifacts and cochlear implant positioning at 3 T in vivo. *Otol Neurotol* 2015;**36**(6):972–6.
14. Schröder D, Grupe G, Rademacher G, et al. Magnetic resonance imaging artifacts and cochlear implant positioning at 1.5 T in vivo. *Biomed Res Int* 2018;**2018**:9163285.
15. Chakrabarty A, Sreevastava D, Bhargava A, et al. Cochlear implant: anaesthesia challenges. *Med J Armed Forces India* 2011;**60**(4):351–6.
16. Migirov L, Wolf M. Magnet removal and reinsertion in a cochlear implant recipient undergoing brain MRI. *ORL* 2013;**75**(1):1–5.
17. The Royal College of Radiologists (RCR). *Magnetic resonance imaging (MRI) equipment, operations and planning in the NHS — report from the clinical imaging board*. 2017. Available at: https://www.rcr.ac.uk/sites/default/files/cib_mri_equipment_report.pdf. [Accessed 19 February 2019].
18. Crane BT, Gottschalk B, Kraut M, et al. Magnetic resonance imaging at 1.5 T after cochlear implantation. *Otol Neurotol* 2010;**31**:1215–20.
19. Kim BG, Kim JW, Park JJ, et al. Adverse events and discomfort during magnetic resonance imaging in cochlear implant recipients. *JAMA Otolaryngol Head Neck Surg* 2015;**141**(1):45–52.
20. Pross SE, Ward BK, Sharon JD, et al. A prospective study of pain from magnetic resonance imaging with cochlear implant magnets *in situ*. *Otol Neurotol* 2018;**39**(2):e80–6.
21. Young NM, Rojas C, Deng J, et al. Magnetic resonance imaging of cochlear implant recipients. *Otol Neurotol* 2016;**37**(6):665–71.
22. Walker B, Norton S, Phillips G, et al. Comparison of MRI in pediatric cochlear implant recipients with and without retained magnet. *Int J Pediatr Otorhinolaryngol* 2018;**109**:44–9.
23. Leong WJC, Yuen HW. Dislocation of cochlear implant magnet during 1.5 Tesla magnetic resonance imaging despite head bandaging, and its repositioning using an endoscopic approach. *J Laryngol Otol* 2018;**132**(10):943–5.
24. Özgür A, Dursun E, Beyazal Çeliker F, et al. Magnet dislocation during 3 T magnetic resonance imaging in a pediatric case with cochlear implant. *Braz J Otorhinolaryngol* 2016 <https://doi.org/10.1016/j.bjorl.2016.04.025>.
25. Broomfield SJ, Da Cruz M, Gibson WPR. Cochlear implants and magnetic resonance scans: a case report and review. *Cochlear Implant. Int* 2013;**14**(1):51–5.
26. Kong SK, Oh SJ, Lee IW, et al. The reversed internal magnet of cochlear implant after magnetic resonance imaging. *Am J Otolaryngol Head Neck Med Surg* 2014;**35**(2):239–41.
27. Cuda D, Murri A, Succo G. Focused tight dressing does not prevent cochlear implant magnet migration under 1.5 Tesla MRI. *Acta Otorhinolaryngol Ital* 2013;**33**(2):133–6.
28. Deneuve S, Loundon N, Leboulanger N, et al. Cochlear implant magnet displacement during magnetic resonance imaging. *Otol Neurotol* 2008;**29**(6):789–90.
29. Todt I, Tittel A, Ernst A, et al. Pain free 3 T MRI scans in cochlear implantees. *Otol Neurotol* 2017;**38**(10):e401–4.
30. Walton J, Donnelly NP, Tam YC, et al. MRI without magnet removal in neurofibromatosis type 2 patients with cochlear and auditory brainstem implants. *Otol Neurotol* 2014;**35**(5):821–5.
31. Hassepas F, Stabenau V, Arndt S, et al. Magnet dislocation: an increasing and serious complication following MRI in patients with cochlear implants. *RoFo* 2014;**186**(7):680–5.
32. Wagner F, Wimmer W, Leidolt L, et al. Significant artifact reduction at 1.5 T and 3 T MRI by the use of a cochlear implant with removable magnet: an experimental human cadaver study. *PLoS One* 2015;**10**(7) <https://doi.org/10.1371/journal.pone.0132483>.
33. Sharon JD, Northcutt BG, Aygun N, et al. Magnetic resonance imaging at 1.5 tesla with a cochlear implant magnet in place: image quality and usability. *Otol Neurotol* 2016;**37**(9):1284–90.
34. Edmonson HA, Carlson ML, Patton AC, et al. MR imaging and cochlear implants with retained internal magnets: reducing artifacts near highly inhomogeneous magnetic fields. *RadioGraphics* 2018;**38**(1):94–106.
35. Majdani O, Leinung M, Rau T, et al. Demagnetization of cochlear implants and temperature changes in 3 T MRI environment. *Otolaryngol Head Neck Surg* 2008;**139**(6):833–9.
36. Jeon JH, Bae MR, Chang JW, et al. Reversing the polarity of a cochlear implant magnet after magnetic resonance imaging. *Auris Nasus Larynx* 2012;**39**(4):415–7.
37. Öztürk E, Doruk C, Orhan KS, et al. A rare complication of cochlear implantation after magnetic resonance imaging: reversion of the magnet. *J Craniofac Surg* 2017;**28**(4):e372–4.